

Senscient ELDS™ OPGD Series 2000 H2S

Fulfilling the promise of open path gas detection (OPGD)

About Senscient ELDS OPGD

ELDS™ is a patented, new open path gas detection (OPGD) technology from Senscient. The innovative Enhanced Laser Diode Spectroscopy (ELDS) detection technology featured in our ELDS Series of open path gas detectors truly fulfills the promise of fit-and-forget open path gas detection...

- **Reliable detection of both toxic & flammable gases.**
- **Industry's first false-alarm free Open Path Gas Detector.** ELDS detection is molecular species specific, eliminating false alarms from common atmospheric or non-hazardous gases that plague traditional OPGD (or any NDIR or LDS technology) systems.
- **FIRST and ONLY laser open path combustible gas detector to meet current industry Safety Standards.**
- **FIRST and ONLY gas detector with SimuGas™, an electronic, remote functionality check.**
- **3 orders of magnitude greater sensitivity for combustible gases versus conventional NDIR-based detectors.**
- **Up to 60% reduction in gas detection project CapEx and OpEx, with true Fit-&-Forget functionality.**
- **Backed by a network of industry-leading gas detection solutions providers.**



Senscient ELDS OPGD Series 2000 H2S Hydrogen Sulfide Detector Features / Benefits:

- Reliable, open path detection of hydrogen sulfide at levels low enough to protect personnel from the toxic hazard.
- Faster response than any other hydrogen sulfide detection technology.
- No need to replace or re-calibrate sensors.
- True ease-of-installation, with vibration and misalignment tolerant optics.
- SimuGas™ feature provides ability to accomplish on-demand, remote functionality testing right from the control room or PLC!
- 316L Stainless steel construction designed to provide maximum corrosion resistance for installation in sea and land-based Hazardous Area facilities.

Applications:

Offshore Platforms, FPSO's, Onshore Petrochemical facilities and Refineries.

Theory of Operation:

Using a separate transmitter and receiver configuration, Senscient ELDS Series 2000 H2S OPGD systems can detect and measure hydrogen sulfide over distances between 5 and 60 m. The ELDS technique measures the Harmonic Fingerprint introduced onto the transmitter's laser beam(s) by absorption by any target gas in the monitored path.



Senscient ELDS™ OPGD Series 2000 H2S

Fulfilling the promise of open path gas detection (OPGD)

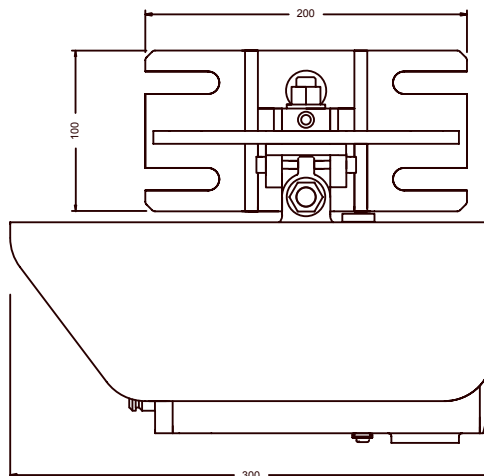
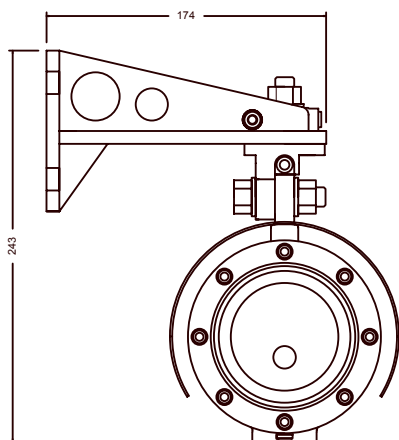

Specifications:

Gas	Hydrogen sulfide
Ranges	0-250 ppm.m (0-100 ppm.m Optional) 0-1000 ppm.m (optional)
Path-Length	5 – 60 m = Short = S

Performance:

Response Time	T90 <= 5 seconds
Resolution	0.5% FSD
Repeatability	= < +/- 2% FSD
Linearity	= < +/- 2% FSD
Zero Drift	= < +/- 1% FSD
Span Drift	= < +/- 2% FSD
Minimum Alarm Threshold	50 ppm.m H2S

Environmental:

Ingress Protection	IP66/67 (Baseefa) Type 4/6 (CSA)
Enclosure Material	316L stainless steel
Operating Temperature	-40° C to +60° C
Humidity	0 – 100% RH (non-condensing)
Vibration	10 – 150 Hz, 2 g
EMC	EN50270
Meteorological Visibility	Operates @ Met. Visibility > = Path-Length

Certification / Approvals:

CSA North America Approval to CSA and UL Standards

Class 1 Div 1 Groups B C & D T5
Class II/III, Div 1, Groups E F & G T5
Ex d IIB + H2 T5
Class I, Zone 1, AEx d IIB + H2 T5
Tamb = -40° C to +60° C
Entry: ¾" NPT

BASEEFA ATEX:

II 2 G Ex d IIB + H2 T5
II 2 D Ex tD A21 T100° C IP66/67
Tamb = -40° C to +60° C
Entry: M25



GOST-K



Safety Integrity - Suitable for use in SIL2 Safety Systems per IEC 61508

Electrical:

Operating Voltage	+24 V nominal, operates correctly for supply voltages between +18 V and +32 V
Power Consumption	TX = 12 W (max), RX = 10 W (max)
Quantity 2 Output	(Analog) 4-20 mA (2 wire, isolated) 0-250 ppm.m on 4-20mA(1) 0-100 ppm.m on 4-20mA(2) Configurable for single wire, sink or source Capable of driving 0-600 Ohm load

Low Signal	3 mA (configurable 1 mA to 4 mA)
Beam Block	2.5 mA (configurable 0 mA to 3.5 mA)
Inhibit	2 mA (configurable 1 mA to 4 mA)
Fault	0 mA
Output (Digital)	HART and MODBUS RTU communication protocols pending

Mechanical:

Size	TX/RX 140 mm dia. x 300 mm
Weight	TX/RX 12 kg each
Mounting	TX & RX units supplied fitted with a mounting bracket which incorporates holes / slots for fixing on flat surfaces or metal poles (4" to 6" diameter - requires U bolts).

Optical:

The unit will operate correctly, without spurious readings or faults during conditions of misalignment or partial obscuration.

Alignment	+/- 0.5°
Obscuration	> 95%
Heated Optics	The window-lenses of the TX and RX units are heated.

Calibration, Testing & Maintenance:

Calibration Units supplied are factory calibrated for the specified target gas or gases. Units should not require re-calibration in service.

Part Numbers:

Senscient ELDS V-GGGG-C

Where:-

V	= S =	Short Range
GGGG	= 2052 =	0-250 ppm.m H2S (0-100 ppm.m optional)
	= 2053 =	0-1000 ppm.m H2S (optional)
C	= 3 =	BASEEFA ATEX
	= 4 =	CSA North America Approval to CSA and UL Standards

E.g. Senscient ELDS S-2052-3 is a short range Senscient ELDS OPGD calibrated for 0-250 ppm.m H2S with BASEEFA ATEX approval.

Distributed by:



Senscient, Inc. • Phone: 1-713-953-8663, or toll-free 1-877-eSIMUGAS (1-877-374-6842)

Email: info@senscient.com • www.Senscient.com

2951 Marina Bay Drive Suite 130-307 • League City, Texas, USA 77573-2785